

Sentry Crash Barrier

Parking Controls | Jacksons Security

Jacksons Fencing

Stowting Common | Ashford | TN25 6BN

www.jacksons-security.co.uk

+44 (0) 1233 750 393

Jacksons
Quality that lasts
Fencing & Access Solutions



Applications

- ✓ Property protection
- ✓ Parking controls

Crash barriers are specifically designed to stop vehicles before they can get close enough to any building wall or fence to do any damage, whether it is accidental, or intentional damage. The barrier is made from sturdy galvanized 100 x 100mm RHS.

Features

- Galvanised as standard with the option of coating
- Rails secured to posts with hidden fixings
- Post centres standard at 1.5m but this can be altered to suit the specific application
- Posts supplied with post cap
- Posts can be supplied with base plates if required
- Posts are 1.5m long 100 x 100mm RHS, 800mm is below ground. Top rails is 6m long 100 x 100mm RHS
- Posts sit on angle iron welded to posts and are predrilled for bolting and are at 1.5m centres

Finish Options

- Galvanized to BS EN 1461 as standard
- Galvanized and powder coated to BS EN 13438 in one of our standard colours at extra cost
- Powder coating to non standard BS or RAL to special order
- Marine coat coating for applications near salt water (optional extra)



Crash Barrier

Specifications and Technical Data

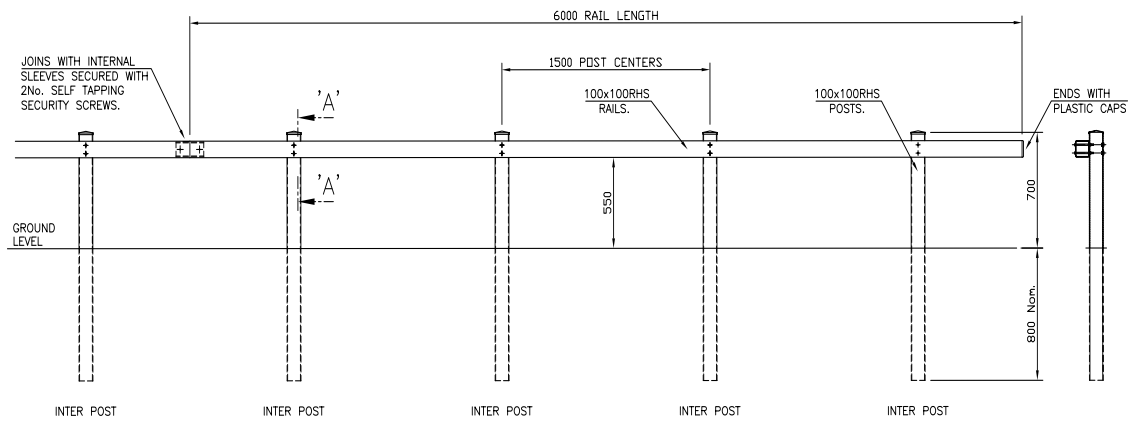
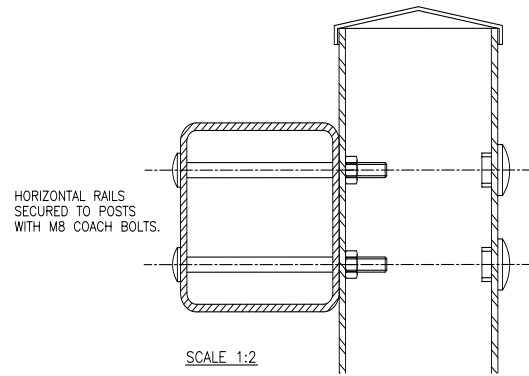

Stepped

